

ProfiCura Gypsum – New Width Measurement Sensor

The ProfiCura Gypsum sensor is the new width and edge profiling sensor for the LIMAB gypsum board measurement system GMS1100.

Compared to its predecessors, the sensors ProfiCura LR Gypsum and Accura VSE, it offers a new design with double optical, anamorphic, lenses for optimized, highly improved performance in both the X- (width) and especially Y-axis (edge profile) measurements.

Technical Specification ProfiCura Gypsum	
Sampling rate	200-2.000 Hz
Resolution X	0,05 ... 0,1 mm (0.002-0.004")
Resolution Y	0,1mm (0.004"), 265 points/profile
Repeat accuracy of width	± 0,1mm (0.004"), 2 σ
Stand off	450 mm (17.7")
Measuring range	600 mm (23.6")
Vertical measuring field	40-80 mm (1.57-3.14")
Laser power	< 25mW
Laser class	3B
Dimensions	515x134x162 mm (20.24x5.28x6.38")

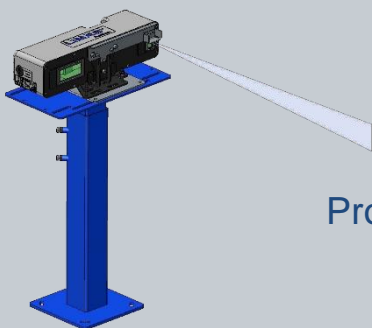

ProfiCura Gypsum mounted on LIMAB floor stand.

It is possible to use new width/edge profile measurement stations in older GMS1100 systems. However, older systems must have their software upgraded in order to integrate the ProfiCura Gypsum sensor.

For the oldest systems we recommend also to replace the system PC's.